



MANUFACTURED IN IRELAND
 www.csc.ie sales@csc.ie
 Phone: 353 (0)1 835 1311
 Fax: +353 (0)1 835 1580

FUME CUPBOARDS

CHEMFLOW SCRUBBER

DESCRIPTION



PRODUCT OVERVIEW

For laboratories where acids such as Perchloric, hydrofluoric, and other water soluble acids are used we offer our **Chemflow Scrubber** cupboard with inbuilt scrubbing system.

By employing our unique tellerette filled scrubbing chamber at the rear of the fume cupboard with its patented water wash down demister jets we can scrub the exhaust fumes with an efficiency of 98%.

We include a recirculation tank and pump and include the option of a neutralisation tank and dosing system which will allow the waste water to be returned to the towns waste system subject to local regulations.

Manufactured to meet and surpass the recommendations laid down in the BS/EN 14175 fume cupboard standards.

OPTIONAL EXTRAS
 Chemflow Scrubber Fume Cupboards come with Energy Save and Acid Storage Units.



CONFIGURATIONS

Model	1200	1500	1800	2000	2400	Other
External Dimensions (WxHxD)	1200x2375 x1120	1500x2375 x1120	1800x2375 x1120	2000x2375 x1120	2400x2375 x1120	Ask
Working Dimensions (WxHxD)	880x1100x720	1180x1100x720	1480x1100x720	1680x1100x720	2080x1100x720	Ask
Outer Skin	6mm PVC	6mm PVC	6mm PVC	6mm PVC	6mm PVC	
Linings	Compact Laminate	Compact Laminate	Compact Laminate	Compact Laminate	Compact Laminate	
Lighting	Fluorescent 400/500 lux Spur Switch	Fluorescent 400/500 lux Spur Switch	Fluorescent 400/500 lux Spur Switch	Fluorescent 400/500 lux Spur Switch	Fluorescent 400/500 lux Spur Switch	
Mains Power	220 v 50 hz	220 v 50 hz	220 v 50 hz	220 v 50 hz	220 v 50 hz	
Twin Electrical Sockets	1	1	2	2	2	
Water & Gas	1	1	2	2	2	
Sash	6mm Toughened	6mm Toughened	6mm Toughened	6mm Toughened	6mm Toughened	Ask
Worktop	Trespa Lab +	Trespa Lab +	Trespa Lab +	Trespa Lab +	Trespa Lab +	Optional
Drip Cup	1 x Vulcathene	1 x Vulcathene	2 x Vulcathene	2 x Vulcathene	2 x Vulcathene	Ask
Airflow Monitor	Standard	Standard	Standard	Standard	Standard	Optional
Frame	Epoxy Steel	Epoxy Steel	Epoxy Steel	Epoxy Steel	Epoxy Steel	Optional
Recircu. Tank/Pump	Standard	Standard	Standard	Standard	Standard	

AVAILABLE OPTIONS

Outer Skin						
Mild Steel	✓	✓	✓	✓	✓	
Stainless Steel	✓	✓	✓	✓	✓	
Polypropylene	✓	✓	✓	✓	✓	
Inner Linings						
PVC	✓	✓	✓	✓	✓	
Polypropylene	✓	✓	✓	✓	✓	
Stainless Steel	✓	✓	✓	✓	✓	
GRP	✓	✓	✓	✓	✓	
Electrical Sockets	✓	✓	✓	✓	✓	
Gas/Water/ Nitrogen	✓	✓	✓	✓	✓	
Ceramic Sink	✓	✓	✓	✓	✓	
PP Sink	✓	✓	✓	✓	✓	
Stainless Sink	✓	✓	✓	✓	✓	
Ceramic Worktop	✓	✓	✓	✓	✓	
Epoxy Resin Worktop	✓	✓	✓	✓	✓	
Steel Steel W.Top	✓	✓	✓	✓	✓	
Polypropylene W.Top	✓	✓	✓	✓	✓	
Atex rating	✓	✓	✓	✓	✓	
Electrical RCB	✓	✓	✓	✓	✓	
Sockets RCB	✓	✓	✓	✓	✓	
Data Points	✓	✓	✓	✓	✓	
Polycarbonate Sash	✓	✓	✓	✓	✓	



FUME CUPBOARDS

CHEMFLOW SCRUBBER



AVAILABLE SIZES
1200, 1500, 1800, 2000, 2200, 2400

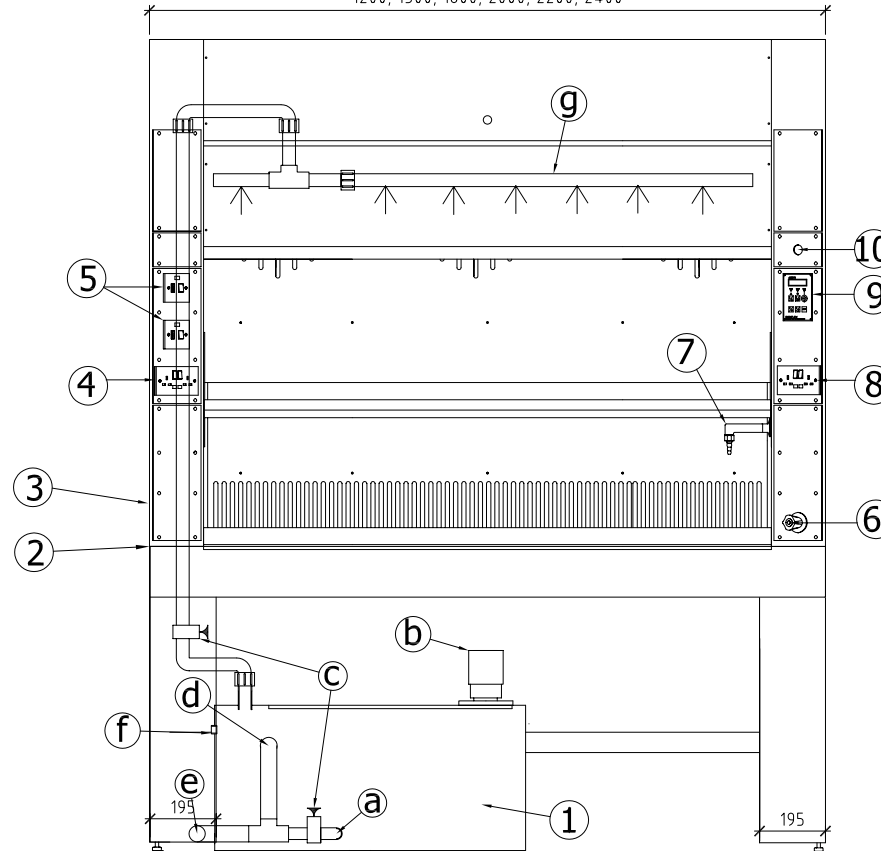

Specification:

1000mm wide Fume Cupboard with Inbuilt scrubber
Approximate External dimensions (W x D x H)mm,
2000 x 1100 x 2400

1: GRP Recirculation tank.

a: 1" Drain

b: Recirculation Pump

c: Ball Valve

d: 1 1/2" Overflow

e: To common drain

f: Ballcock feed from mains 1/2" connection

g: Spray header

2: Epoxy coated mild steel frame

3: Fume Cupboard

4: 13A, 220V, Switched twin socket

5: Fused recirc pump & light switch

6: Remote cold water valve

7: Water Outlet

8: 13A, 220V, Switched twin socket

9: "Chemflow" airflow monitor

10: Airflow Sensor